



PARTS CATALOGUE

PW50 (5PGN) EUROPE, SOUTH AFRICA, JAPAN

PW50Z (5PGP) OCEANIA



1J5PG-300E1

()

PW50/PW50Z
PARTS CATALOGUE
©2009 by Yamaha Motor Co., Ltd.
1st edition, May 2009
All rights reserved.
Any reprinting or unauthorized use
without the written permission of
Yamaha Motor Co., Ltd.
is expressly prohibited.
Printed in Japan.

FOREWORD

This Parts Catalogue is related to the parts for the model(s) on the cover page. When you are ordering replacement parts, please refer to this Parts Catalogue and quote both part numbers and part names correctly.

1. Modifications or additions which have been made after the issue of the Parts Catalogue will be announced in the Parts News.

It is advisable that you make the necessary corrections to the Parts Catalogue according to the Parts News.

2. Abbreviations

The following abbreviations are used in this Parts Catalogue.

“UR” Use specified parts number.

“UN” Use as many as needed.

“AP” Alternate Parts

“LM” Locally Made (Parts need to be ordered locally)

“F#” Frame No. (Applicable machine No.)

“O/S” Over Size

3. The number of components for assembly

- Parts, which are to be supplied in an assembly, are listed with a dot (.) in front of the part name as shown below.
- The numeral appearing to the right of each component part indicates the quantity of parts for each assembly unit.

PART NO.	DESCRIPTION	Q'TY	REMARKS
2F5-83310-60	FRONT FLASHER LIGHT ASSY	2	
115-83311-60	.BULB (6V-18W)	1	

4. Applicable colours of graphics are represented in the “REMARKS” as shown below.

PART NO.	DESCRIPTION	Q'TY	REMARKS
2N4-24110-00-X5	FUEL TANK COMP.	2	MXR
3J1-24240-10	.GRAPHIC, FUEL TANK	1	FOR MXR

5. Note that the illustrations for reference in finding parts numbers are not to be used for assembling. When assembling, please use the applicable service manual.

6. The asterisk (*) before a reference number indicates modified items after the first edition.

FOREWORD

7. Applicable Serial No.

Engine Serial No.

Frame Serial No.

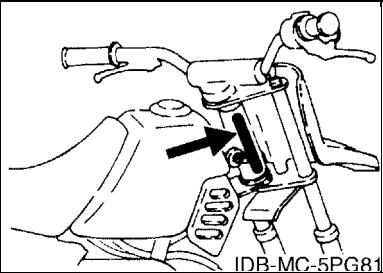
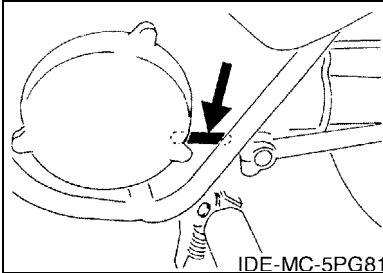

8. Applicable Colour Code (The (*) mark shows Model colour.)

Abbreviation	Colour Name	Colour Code
DPBSE(*)	DEEP PURPLISH BLUE SOLID E	0583
LGB	LOW GLOSS BLACK	0098
RW	RADICAL WHITE	00UJ
SL	SILVER	0035
YB	YAMAHA BLACK	0033

CONTENTS

ENGINE

CYLINDER	1
CRANKSHAFT & PISTON	2
OIL PUMP	3
INTAKE	4
CARBURETOR	5
EXHAUST	7
CRANKCASE	8
STARTER	9
CLUTCH	10
TRANSMISSION	11

CHASSIS

FRAME	12
FRONT FENDER	13
SIDE COVER	14
OIL TANK	15
REAR ARM & SUSPENSION	16
DRIVE SHAFT	17
FRONT FORK	18
FUEL TANK	19
SEAT	20
FRONT WHEEL	21
REAR WHEEL	22
STEERING HANDLE & CABLE	23
STAND & FOOTREST	24
GENERATOR	25
HANDLE SWITCH & LEVER	26
ELECTRICAL 1	27

INDEX

NUMERICAL INDEX	28
-----------------------	----

FIG. 1 CYLINDER

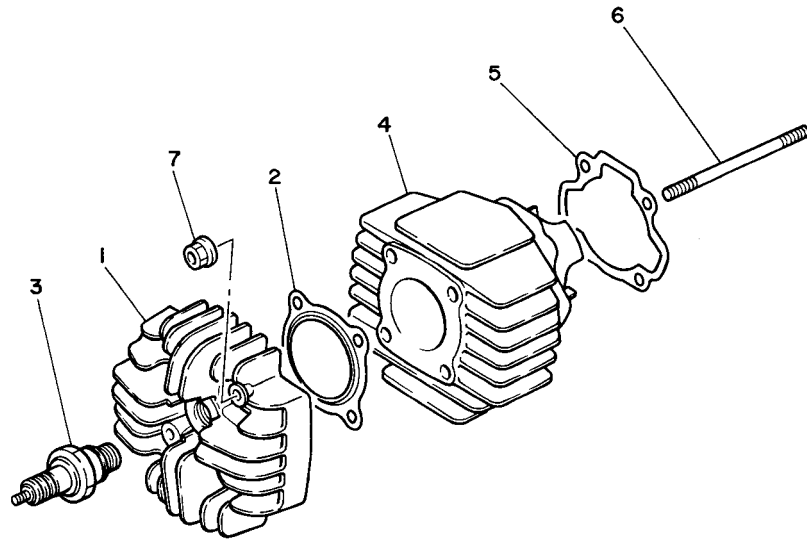

REF. NO.	PART NO.	DESCRIPTION	EUR	ZAF	JPN	OCE	REMARKS
1	4J2-11111-00	HEAD, CYLINDER 1	1	1	1	1	
2	517-11181-01	GASKET, CYLINDER HEAD 1	1	1	1	1	
3	94701-00258	PLUG, SPARK (NGK BPR4HS)	1	1			
	94703-00258	PLUG, SPARK (NGK BPR4HS)			1		
	94701-00159	PLUG, SPARK (NGK BP4HS)				1	UR
	94701-00171	PLUG, SPARK (ND W14FP-L)				1	UR
4	4J2-11311-00	CYLINDER 1	1	1	1	1	
5	3PT-11351-00	GASKET, CYLINDER	1	1	1	1	
6	90116-06418	BOLT, STUD	4	4	4	4	
7	95707-06500	NUT, FLANGE	4	4	4	4	



3PT110-0010

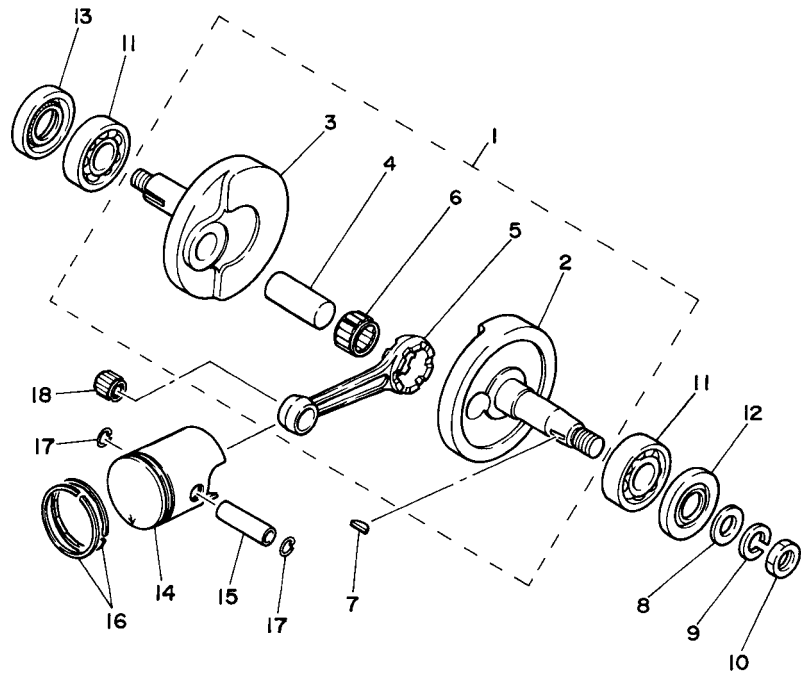

3PT110-0020

FIG. 2 CRANKSHAFT & PISTON

REF. NO.	PART NO.	DESCRIPTION	EUR	ZAF	JPN	OCE	REMARKS
1	3L5-11400-01	CRANKSHAFT ASSY	1	1	1	1	
2	3L5-11412-00	.CRANK 1	1	1	1	1	
3	3L5-11422-01	.CRANK 2	1	1	1	1	
4	54U-11681-00	.PIN, CRANK 1	1	1	1	1	
5	2E9-11651-00	.ROD, CONNECTING	1	1	1	1	
6	93310-416N7	.BEARING	1	1	1	1	
7	90280-03017	KEY, WOODRUFF	1	1	1	1	
8	92907-12600	WASHER, PLATE	1	1	1	1	
9	92907-12100	WASHER, SPRING	1	1	1	1	
10	95307-12700	NUT	1	1	1	1	
11	93306-20326	BEARING	2	2	2	2	
12	93102-17067	OIL SEAL	1	1	1	1	
13	93102-23174	OIL SEAL	1	1	1	1	
14	18U-11631-00-A0	PISTON (STD)	1	1	1	1	
	18U-11635-00	PISTON (0.25MM O/S)	1	1	1	1	AP
	18U-11636-00	PISTON (0.50MM O/S)	1	1	1	1	AP
15	3L5-11633-00	PIN, PISTON	1	1	1	1	
16	260-11610-04	PISTON RING SET (STD)	1	1	1	1	
	260-11610-14	PISTON RING SET (0.25MM O/S)	1	1	1	1	AP
	260-11610-24	PISTON RING SET (0.50MM O/S)	1	1	1	1	AP
17	93450-11021	CIRCLIP	2	2	2	2	
18	93310-21038	BEARING	1	1	1	1	

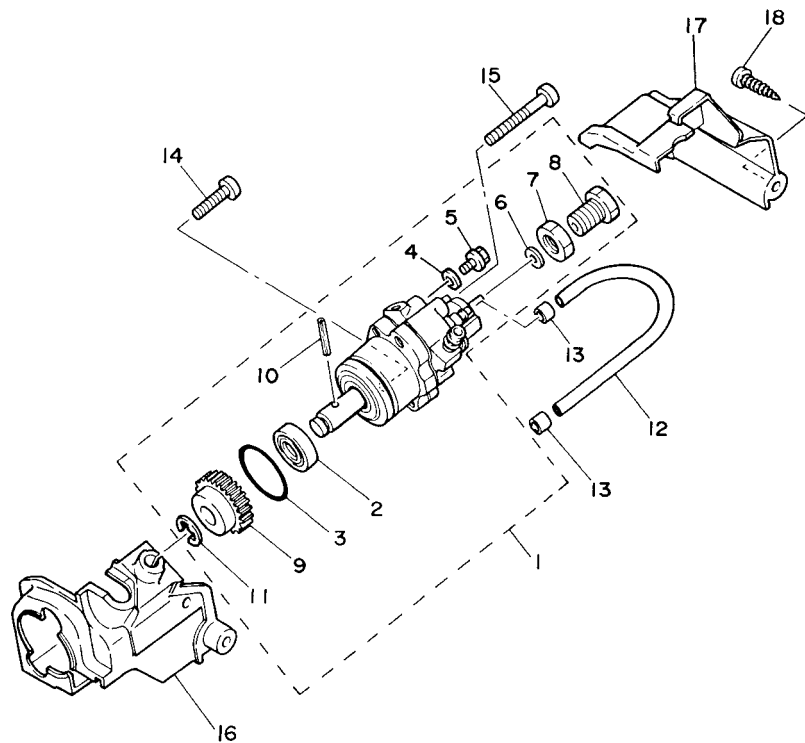

3PT110-0030

FIG. 3 OIL PUMP

REF. NO.	PART NO.	DESCRIPTION	EUR	ZAF	JPN	OCE	REMARKS
1	3L5-13101-01	OIL PUMP ASSY	1	1	1	1	
2	93101-10001	.OIL SEAL	1	1	1	1	
3	93210-26240	.O-RING	1	1	1	1	
4	90430-04004	.GASKET	1	1	1	1	
5	90149-04135	.SCREW	1	1	1	1	
6	384-13138-00	.PLATE, ADJUSTING	1	1	1	1	
7	90170-10105	.NUT	1	1	1	1	
8	90401-10029	.BOLT, UNION	1	1	1	1	
9	3L5-13124-00	.GEAR, WORM WHEEL (56T)	1	1	1	1	
10	91609-30014	.PIN, SPRING	1	1	1	1	
11	93430-07012	.CIRCLIP	1	1	1	1	
12	3L5-13161-00	PIPE, DELIVERY 1	1	1	1	1	
13	90468-02033	CLIP	2	2	2	2	
14	98507-05020	SCREW, PAN HEAD	1	1	1	1	
15	98507-05035	SCREW, PAN HEAD	1	1	1	1	
16	3L5-15416-00	COVER, OIL PUMP	1	1	1	1	
17	3L5-15426-00	COVER, OIL PUMP 2	1	1	1	1	
18	97707-50115	SCREW, TAPPING	1	1	1	1	

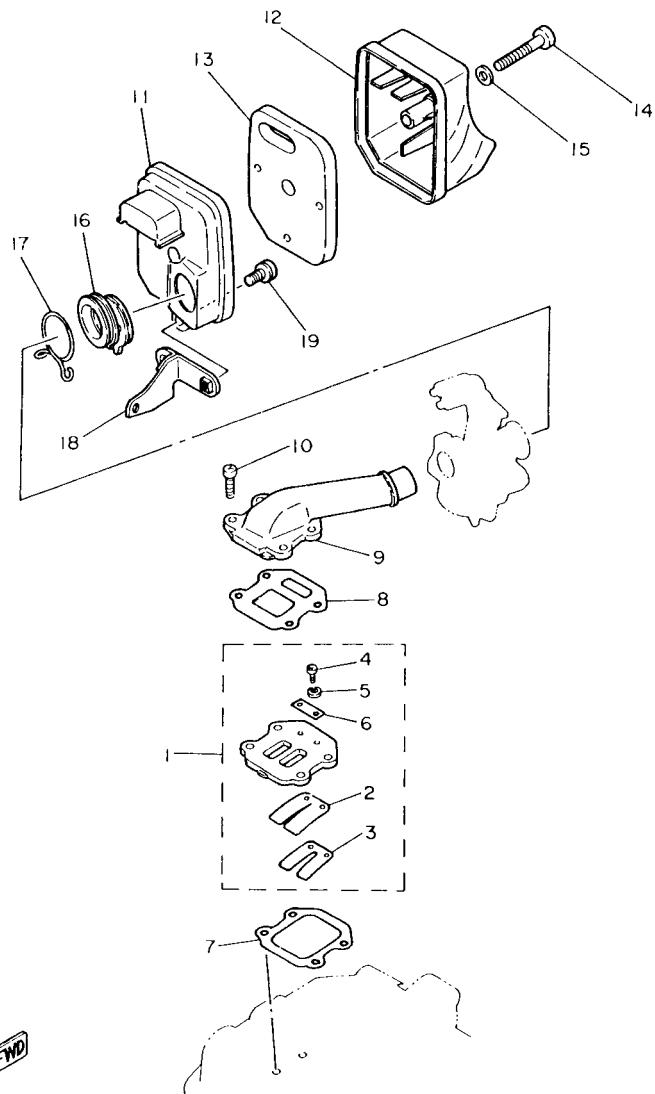

3PT110-1040

FIG. 4 INTAKE

REF. NO.	PART NO.	DESCRIPTION	EUR	ZAF	JPN	OCE	REMARKS
1	3L5-13610-00	REED VALVE ASSY	1	1	1	1	
2	3L5-13613-00	.REED, VALVE	1	1	1	1	
3	3L5-13616-00	.STOPPER, REED VALVE	1	1	1	1	
4	98507-03010	.SCREW, PAN HEAD	2	2	2	2	
5	92907-03100	.WASHER, SPRING	2	2	2	2	
6	3L5-13624-00	.PLATE, REED VALVE	1	1	1	1	
7	3HK-13621-00	GASKET, VALVE SEAT	1	1	1	1	
8	3L5-13622-10	GASKET, VALVE SEAT	1	1	1	1	
9	3L5-13555-00	MANIFOLD, INTAKE	1	1	1	1	
10	98507-06020	SCREW, PAN HEAD	4	4	4	4	
11	4X4-14411-00	CASE, AIR CLEANER 1	1	1	1	1	
12	4X4-14412-00	CAP, CLEANER CASE 1	1	1	1	1	
13	4X4-14451-00	ELEMENT, AIR CLEANER	1	1	1	1	
14	98507-06045	SCREW, PAN HEAD	1	1	1	1	
15	92907-06600	WASHER, PLATE	1	1	1	1	
16	4X4-14453-00	JOINT, AIR CLEANER 1	1	1	1	1	
17	90467-20023	CLIP	1	1	1	1	
18	4X4-14493-01	STAY 1	1	1	1	1	
19	90159-06013	SCREW, WITH WASHER	1	1	1	1	

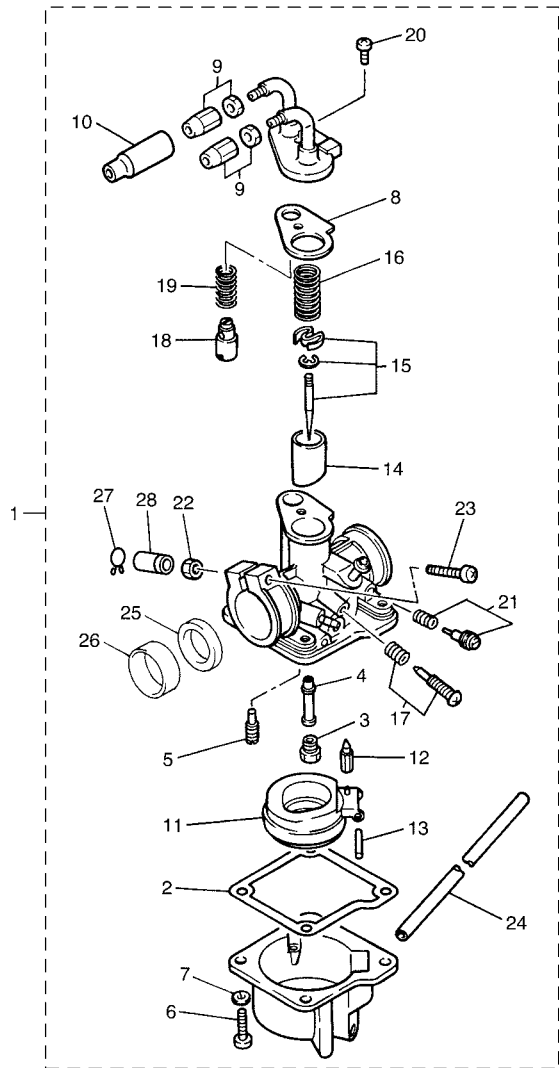

5PGJ110-H050

FIG. 5 CARBURETOR

REF. NO.	PART NO.	DESCRIPTION	EUR	ZAF	JPN	OCE	REMARKS
1	5PG-14101-10	CARBURETOR ASSY 1	1	1	1	1	
2	3L5-14184-00	.GASKET, FLOAT CHAMBER	1	1	1	1	
3	620-14231-14	.JET, MAIN (# 70)	1	1	1	1	
4	3L7-14141-12	.NOZZLE, MAIN	1	1	1	1	
5	3L5-14142-40	.JET, PILOT (# 40)	1	1	1	1	
6	98507-04014	.SCREW, PAN HEAD	4	4	4	4	
7	92907-04100	.WASHER, SPRING	4	4	4	4	
8	3L5-14198-00	.GASKET	1	1	1	1	
9	17L-14106-00	.CABLE ADJUST SCREW SET	2	2	2	2	
10	1R0-14169-00	.CAP	1	1	1	1	
11	3L6-14185-01	.FLOAT	1	1	1	1	
12	3L5-14190-01	.NEEDLE VALVE ASSY	1	1	1	1	
13	603-14186-00	.PIN, FLOAT	1	1	1	1	
14	3L5-14112-40	.VALVE, THROTTLE 1	1	1	1	1	
15	5PG-1490J-00	.NEEDLE SET	1	1	1	1	
16	174-14131-01	.SPRING, THROTTLE VALVE	1	1	1	1	
17	36R-14103-00	.THROTTLE SCREW SET	1	1	1	1	
18	127-14171-00	.PLUNGER, STARTER	1	1	1	1	
19	127-14135-00	.COIL, SPRING	1	1	1	1	
20	98607-05112	.SCREW, OVAL HEAD	1	1	1	1	
21	36R-14104-00	.AIR SCREW SET	2	2	2	2	
22	98807-05100	.NUT	1	1	1	1	
23	98507-05030	.SCREW, PAN HEAD	1	1	1	1	
24	214-14197-00	.PIPE	1	1	1	1	
25	1M3-14997-00	.SEAL	1	1	1	1	
26	1V3-14271-00	.INSULATOR	1	1	1	1	
27	55X-14937-00	.CLIP	1	1	1	1	

FIG. 6 EXHAUST

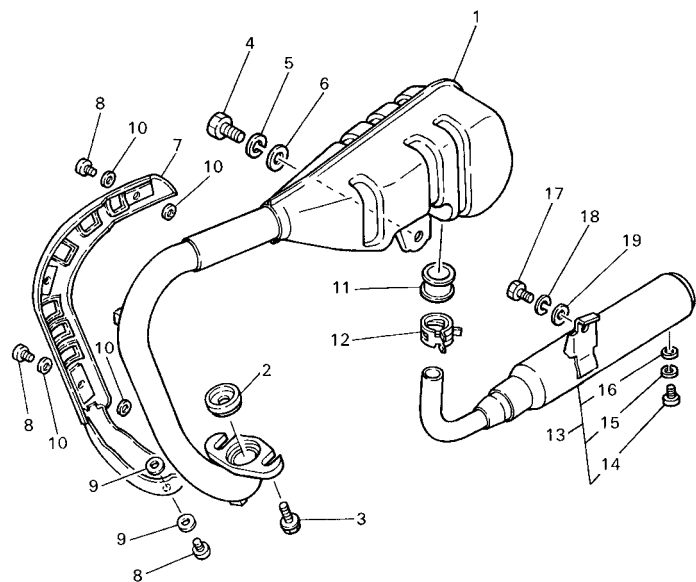

3PT100-5060

REF. NO.	PART NO.	DESCRIPTION	EUR	ZAF	JPN	OCE	REMARKS
1	4X4-14610-01	EXHAUST PIPE ASSY 1	1	1	1	1	
2	4X4-14623-10	GASKET, EXHAUST PIPE	1	1	1	1	
3	90153-06011	SCREW, HEXAGON	2	2	2	2	
4	97007-08020	BOLT	1	1	1	1	
5	92907-08100	WASHER, SPRING	1	1	1	1	
6	92907-08600	WASHER, PLATE	1	1	1	1	
7	4X4-14708-00	PROTECTOR ASSY	1	1	1	1	
8	90157-05003	SCREW, PAN HEAD	4	4	4	4	
9	90202-04214	WASHER, PLATE	2	2	2	2	
10	3RV-14766-00	WASHER, PROTECTOR	6	6	6	6	
11	4X4-14714-00	GASKET, MUFFLER	1	1	1	1	
12	90467-22048	CLIP	1	1	1	1	
13	4X4-14750-00	SILENCER ASSY	1	1	1	1	
14	98507-06008	.SCREW, PAN HEAD	1	1	1	1	
15	92907-06100	.WASHER, SPRING	1	1	1	1	
16	92907-06600	.WASHER, PLATE	1	1	1	1	
17	97007-06016	BOLT	1	1	1	1	
18	92907-06100	WASHER, SPRING	1	1	1	1	
19	92907-06600	WASHER, PLATE	1	1	1	1	

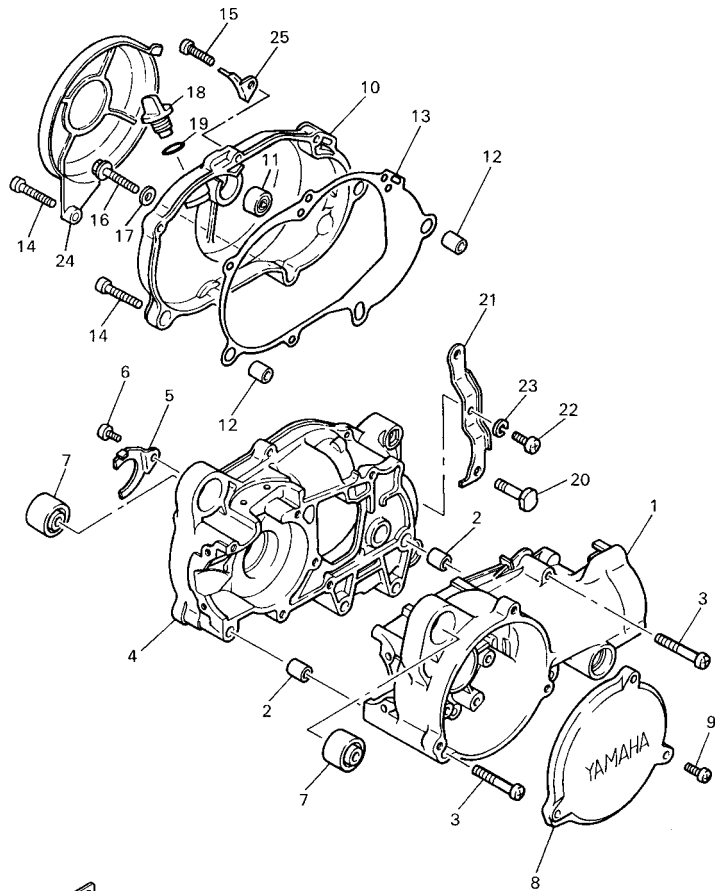

3PT100-5070

FIG. 7 CRANKCASE

REF. NO.	PART NO.	DESCRIPTION	EUR	ZAF	JPN	OCE	REMARKS
1	4X4-15111-00	CRANKCASE 1	1	1	1	1	
2	99530-12016	PIN, DOWEL	2	2	2	2	
3	98507-06045	SCREW, PAN HEAD	8	8	8	8	
4	4J2-15121-01	CRANKCASE 2	1	1	1	1	
5	3L5-15128-00	HOLDER	1	1	1	1	
6	98507-06012	SCREW, PAN HEAD	1	1	1	1	
7	2E9-15316-00	DAMPER 1	2	2	2	2	
8	4J2-15415-00	COVER, GENERATOR	1	1	1	1	
9	98507-05014	SCREW, PAN HEAD	3	3	3	3	
10	4X4-15421-02	COVER, CRANKCASE 2	1	1	1	1	
11	3L5-17112-01	BUSH 1	1	1	1	1	
12	99530-12016	PIN, DOWEL	2	2	2	2	
13	3L5-15451-11	GASKET, CRANKCASE COVER 1	1	1	1	1	
14	98507-06035	SCREW, PAN HEAD	3	3	3	3	
15	98507-06025	SCREW, PAN HEAD	3	3	3	3	
16	90105-08103	BOLT, FLANGE	1	1	1	1	
17	90430-08119	GASKET	1	1	1	1	
18	4J2-15363-10	PLUG, OIL	1	1	1	1	
19	93210-14104	O-RING	1	1	1	1	
20	90109-08582	BOLT	2	2	2	2	
21	4J2-15113-00	PLATE	1	1	1	1	
22	98507-06012	SCREW, PAN HEAD	1	1	1	1	
23	92907-06100	WASHER, SPRING	1	1	1	1	
24	4X4-15491-00	PROTECTOR	1	1	1	1	
25	4X4-15484-00	CLAMP 2	1	1	1	1	

FIG. 8 STARTER

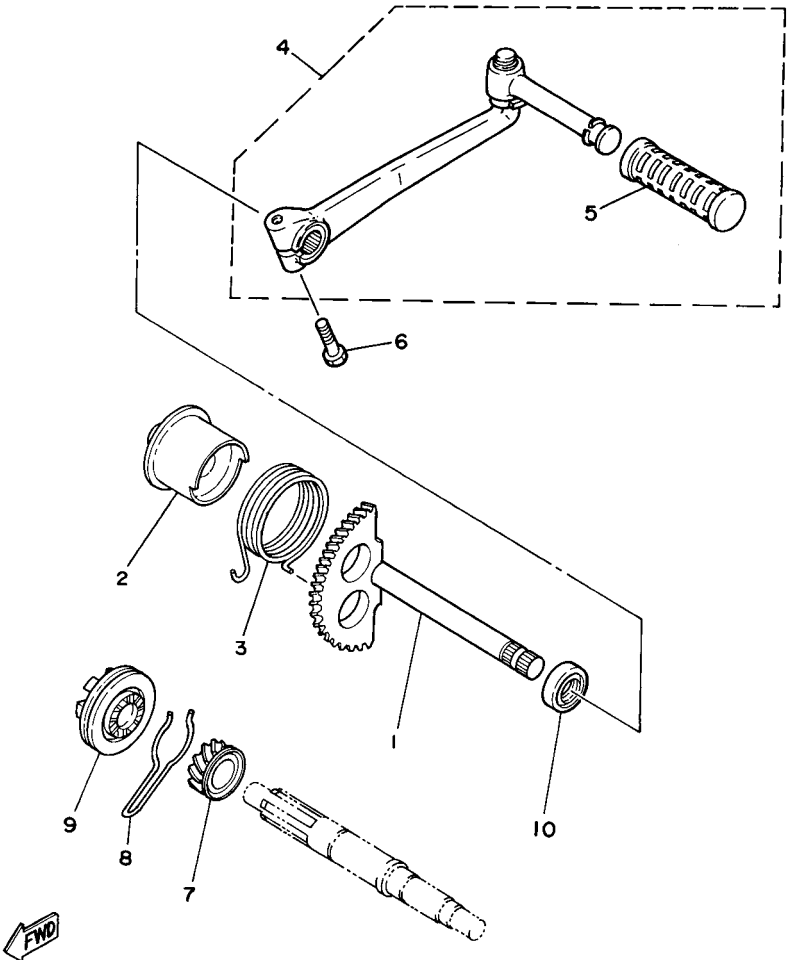

3PT110-0080

REF. NO.	PART NO.	DESCRIPTION	EUR	ZAF	JPN	OCE	REMARKS
1	3L5-15601-00	KICK SHAFT ASSY	1	1	1	1	
2	3L5-15664-00	GUIDE, SPRING	1	1	1	1	
3	90508-28399	SPRING, TORSION	1	1	1	1	
4	17J-15620-01	KICK CRANK ASSY	1	1	1	1	
5	2T4-15618-00	.COVER, KICK LEVER	1	1	1	1	
6	97017-06025	BOLT	1	1	1	1	
7	3L5-15631-00	GEAR, KICK PINION (13T)	1	1	1	1	
8	3L5-15673-00	CLIP	1	1	1	1	
9	3L5-13178-00	GEAR, PUMP DRIVE	1	1	1	1	
10	93109-15001	OIL SEAL	1	1	1	1	

FIG. 9 CLUTCH

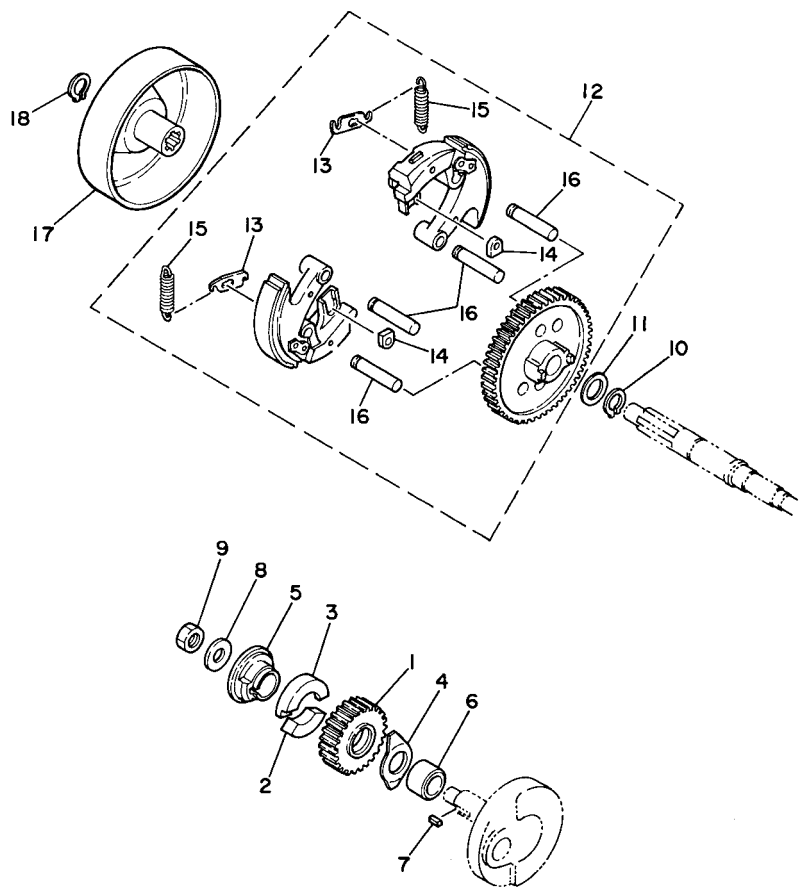

REF. NO.	PART NO.	DESCRIPTION	EUR	ZAF	JPN	OCE	REMARKS
1	3L5-16111-00	GEAR, PRIMARY DRIVE (33T)	1	1	1	1	
2	3L5-16115-00	ABSORBER 1	1	1	1	1	
3	3L5-16125-00	ABSORBER 2	1	1	1	1	
4	3L5-16114-00	PLATE, THRUST 2	1	1	1	1	
5	3L5-16181-01	SPACER 1	1	1	1	1	
6	90387-16730	COLLAR	1	1	1	1	
7	90282-05034	KEY, STRAIGHT	1	1	1	1	
8	90208-10012	WASHER, CONICAL SPRING	1	1	1	1	
9	90170-10206	NUT	1	1	1	1	
10	99009-16400	CIRCLIP	1	1	1	1	
11	90201-16383	WASHER, PLATE	1	1	1	1	
12	3L5-16620-03	CLUTCH CARRIER ASSY	1	1	1	1	
13	3L5-16628-02	.WASHER	2	2	2	2	
14	2T4-16629-00	.DAMPER, CLUTCH WEIGHT	2	2	2	2	
15	3L5-16627-02	.SPRING, CLUTCH WEIGHT 2	2	2	2	2	
16	3L5-16633-02	.SHAFT, CLUTCH WEIGHT	4	4	4	4	
17	3L5-16611-02	CLUTCH HOUSING COMP.	1	1	1	1	
18	99009-16400	CIRCLIP	1	1	1	1	



3PT110-0090

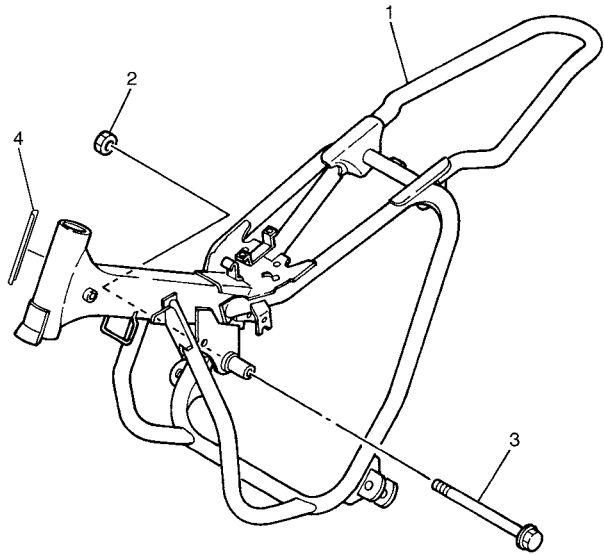

5PGG300-G110

FIG. 11 FRAME

REF. NO.	PART NO.	DESCRIPTION	EUR	ZAF	JPN	OCE	REMARKS
1	36E-21110-01-33	FRAME COMP.	1	1	1	1	YB
2	95607-10200	NUT, U FLANGE	1	1	1	1	
3	90105-10110	BOLT, FLANGE	1	1	1	1	
4	3HA-24141-00	PROTECTOR, FUEL TANK	1	1	1	1	

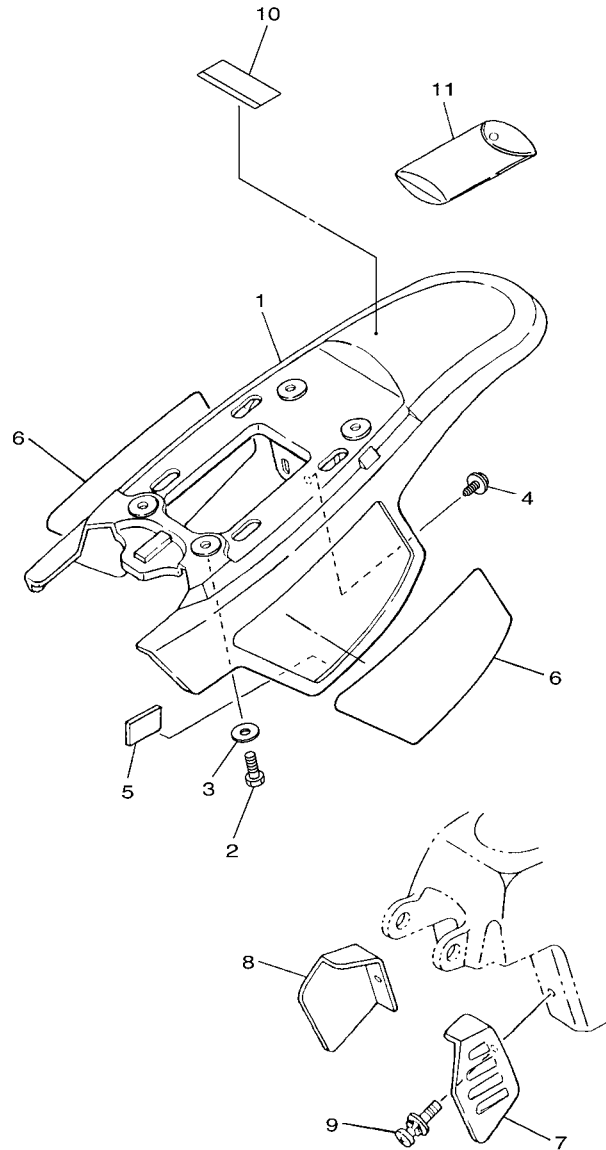

5PGN300-J130

FIG. 13 SIDE COVER

REF. NO.	PART NO.	DESCRIPTION	EUR	ZAF	JPN	OCE	REMARKS
1	3PT-21711-10	COVER, SIDE 1	1	1	1	1	
2	97002-06016	BOLT	4	4	4	4	
3	90201-06033	WASHER, PLATE	4	4	4	4	
4	90119-06226	BOLT, WITH WASHER	2	2	2	2	
5	4X4-24181-00	DAMPER, LOCATING 1	2	2	2	2	
6	3PT-2173L-B0	GRAPHIC SET 1	1	1	1	1	
7	3PT-21731-60	COVER, SIDE 3	1	1	1	1	
8	3PT-21741-60	COVER, SIDE 4	1	1	1	1	
9	90159-06058	SCREW, WITH WASHER	2	2	2	2	
10	5PG-2816R-00	LABEL, WARNING GENERAL INFO.	1				
	5PA-21568-01	LABEL, WARNING		1		1	
11	4X4-28100-00	TOOL KIT	1	1	1	1	

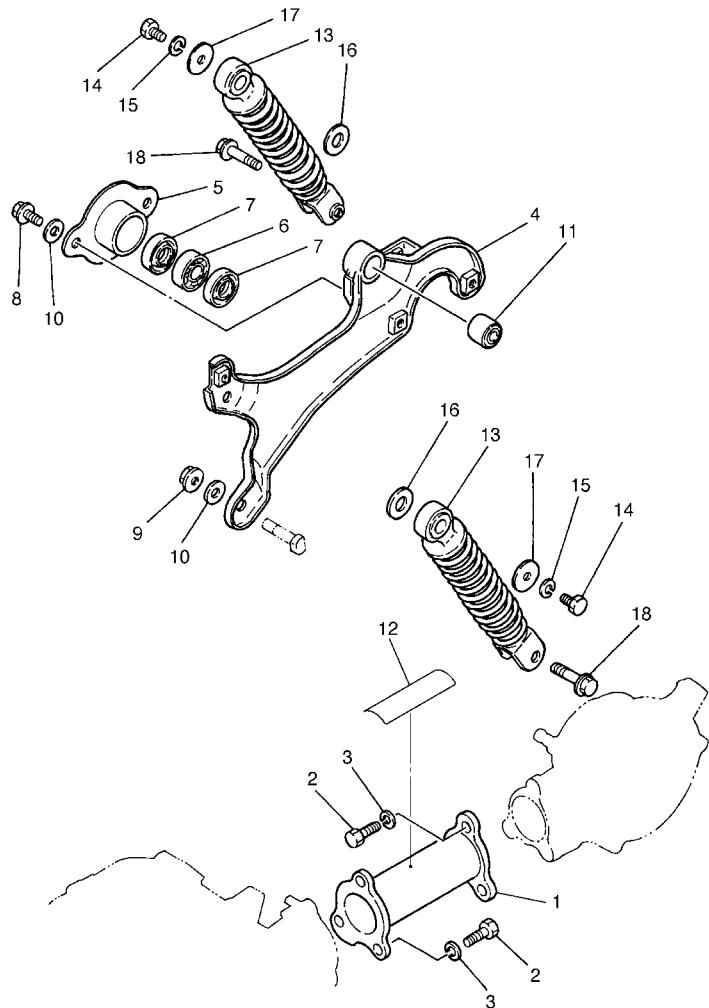

5PGC300-E150

FIG. 15 REAR ARM & SUSPENSION

REF. NO.	PART NO.	DESCRIPTION	EUR	ZAF	JPN	OCE	REMARKS
1	3L7-22110-00-98	REAR ARM COMP.	1	1	1	1	LGB
2	90101-08461	BOLT	6	6	6	6	
3	92907-08100	WASHER, SPRING	6	6	6	6	
4	4X4-22110-10	REAR ARM COMP.	1	1	1	1	
5	4J2-22174-01	END 1	1	1	1	1	
6	93306-20117	BEARING	1	1	1	1	
7	93106-24018	OIL SEAL	2	2	2	2	
8	90105-08066	BOLT, FLANGE	2	2	2	2	
9	95707-08500	NUT, FLANGE	2	2	2	2	
10	90201-08326	WASHER, PLATE	4	4	4	4	
11	164-22216-00	BUSH, REAR SHOCK ABSORBER	1	1	1	1	
12	3RV-21668-A0	LABEL, TIRE		1		1	FOR JAPAN
	3XJ-21668-10	LABEL, TIRE			1		
13	3PT-22210-10	SHOCK ABSORBER ASSY, REAR	2	2	2	2	
14	97027-06016	BOLT, HEXAGON	2	2	2	2	
15	92907-06100	WASHER, SPRING	2	2	2	2	
16	90201-126A7	WASHER, PLATE	2	2	2	2	
17	90201-067A0	WASHER, PLATE	2	2	2	2	
18	90105-08121	BOLT, FLANGE	2	2	2	2	

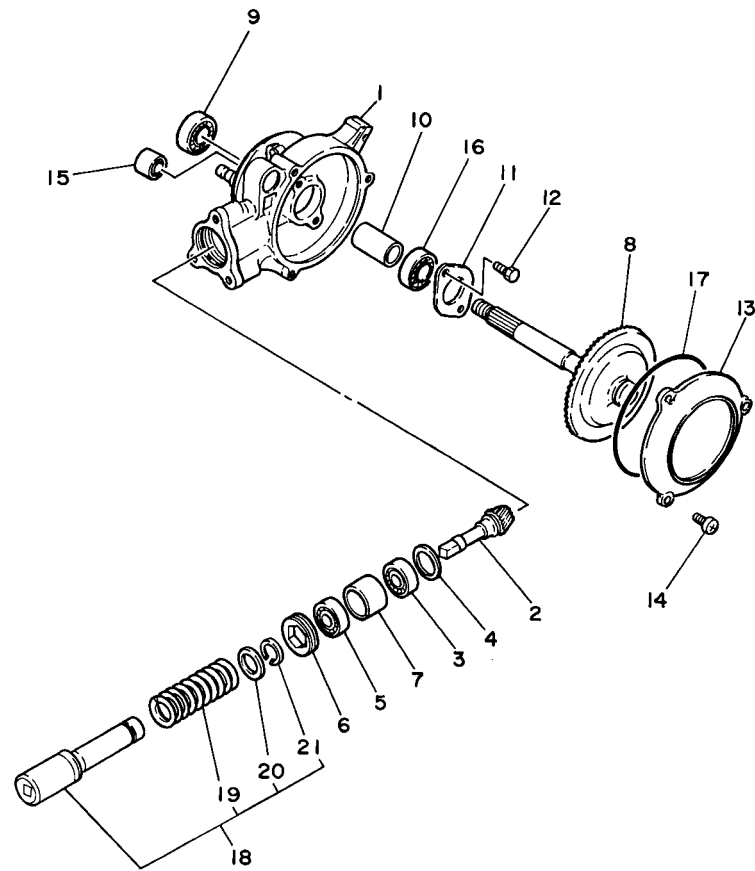

3PT110-0160

FIG. 16 DRIVE SHAFT

REF. NO.	PART NO.	DESCRIPTION	EUR	ZAF	JPN	OCE	REMARKS
1	4J2-46151-01	HOUSING, DRIVE SHAFT	1	1	1	1	
2	59M-46121-00	GEAR, DRIVE PINION	1	1	1	1	
3	93306-20111	BEARING	1	1	1	1	
4	3L5-46127-00	SHIM, DRIVE PINION	1	1	1	1	
5	93306-20111	BEARING	1	1	1	1	
6	90149-35133	SCREW	1	1	1	1	
7	90560-25185	SPACER	1	1	1	1	
8	4J2-46110-01	RING GEAR COMP.	1	1	1	1	
9	93306-20203	BEARING	1	1	1	1	
10	90560-15315	SPACER	1	1	1	1	
11	3L5-46114-00	PLATE, COVER	1	1	1	1	
12	97017-06016	BOLT	2	2	2	2	
13	4J2-46154-02	COVER, HOUSING	1	1	1	1	
14	95027-06016	BOLT, FLANGE	3	3	3	3	
15	164-22216-00	BUSH, REAR SHOCK ABSORBER	1	1	1	1	
16	93306-20205	BEARING	1	1	1	1	KOYO
17	93211-066A9	O-RING	1	1	1	1	
18	3L7-46171-00	SHAFT DRIVE ASSY	1	1	1	1	
19	90501-60556	.SPRING, COMPRESSION	1	1	1	1	
20	15L-18473-00	.RETAINER, SPRING	1	1	1	1	
21	93440-17138	.CIRCLIP	1	1	1	1	

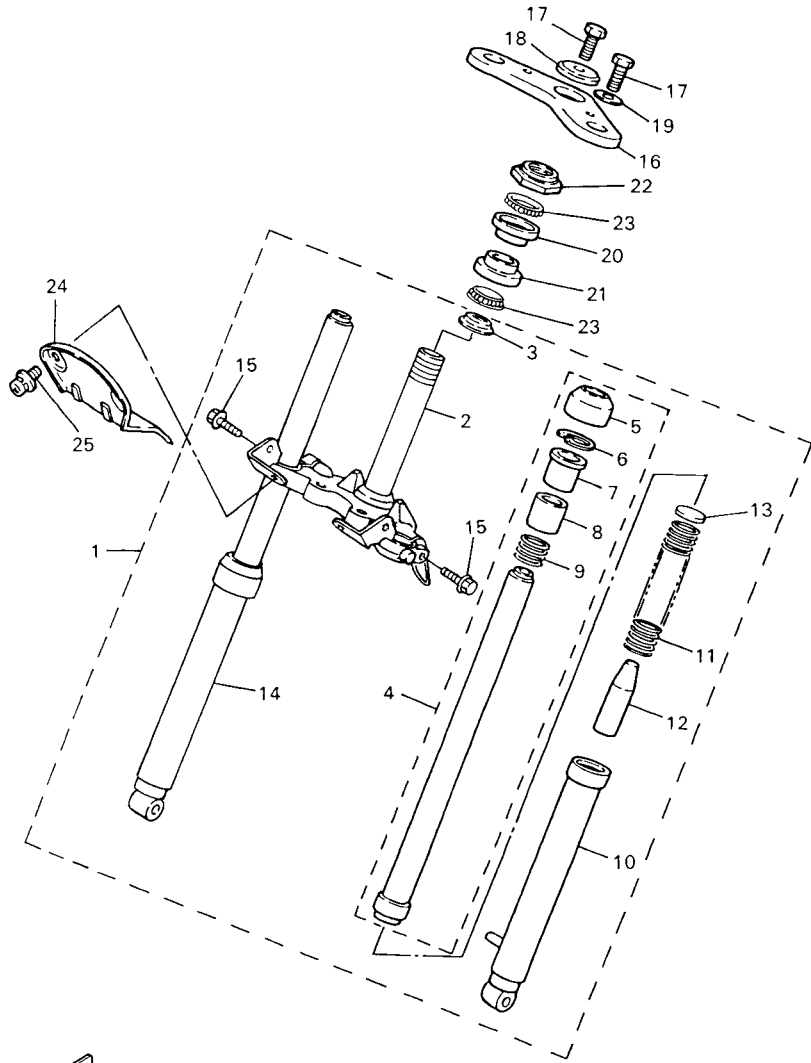

5PG2300-1170

FIG. 17 FRONT FORK

REF. NO.	PART NO.	DESCRIPTION	EUR	ZAF	JPN	OCE	REMARKS
1	3PT-23100-01-35	FRONT FORK ASSY	1	1	1	1	SL
2	3PT-23340-00	.UNDER BRACKET COMP.	1	1	1	1	
3	3YJ-23414-00	.RACE, BALL 4	1	1	1	1	
4	3PT-23110-00	.INNER TUBE COMP.1	1	1	1	1	
5	2E9-23144-01	..SEAL, DUST	1	1	1	1	
6	93450-30057	..CIRCLIP	1	1	1	1	
7	54V-23125-02	..METAL, SLIDE 1	1	1	1	1	
8	2E9-23113-01	..COLLAR	1	1	1	1	
9	36R-23151-00	..SPRING, REBOUND	1	1	1	1	
10	4X4-23106-00-35	.OUTER TUBE COMP. (L.H)	1	1	1	1	SL
11	4X4-23141-00	.SPRING, FRONT FORK	1	1	1	1	
12	3L6-23195-00	.RUBBER	1	1	1	1	
13	2E9-23143-00	.SEAT, SPRING LOWER	1	1	1	1	
14	3PT-23103-00-35	.FRONT FORK ASSY (R.H)	1	1	1	1	SL
15	95027-08030	.BOLT, FLANGE	2	2	2	2	
16	4X4-23435-00	CROWN, HANDLE	1	1	1	1	
17	90105-10006	BOLT, FLANGE	3	3	3	3	
18	90209-10160	WASHER	1	1	1	1	
19	90201-105H3	WASHER, PLATE	2	2	2	2	
20	2E9-23412-00	RACE, BALL 2	1	1	1	1	
21	2E9-23413-01	RACE, BALL 3	1	1	1	1	
22	3PT-23411-00	RACE, BALL 1	1	1	1	1	
23	93505-32042	BALL	2	2	2	2	
24	4X4-21543-00	PLATE 1	1	1	1	1	
25	90159-06060	SCREW, WITH WASHER	2	2	2	2	

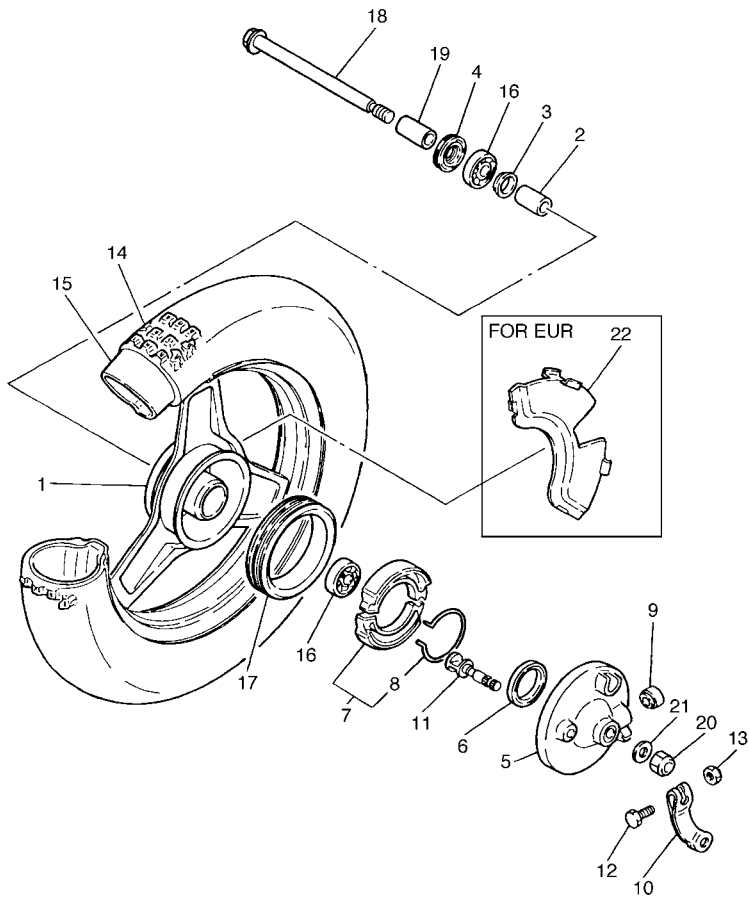

5PG8300-C200

FIG. 20 FRONT WHEEL

REF. NO.	PART NO.	DESCRIPTION	EUR	ZAF	JPN	OCE	REMARKS
1	5M0-25180-00-UJ	WHEEL COMP.	1	1	1	1	RW
2	90560-10173	SPACER	1	1	1	1	
3	2E9-25116-00	FLANGE, SPACER 2	1	1	1	1	
4	93106-17015	OIL SEAL	1	1	1	1	
5	2T4-25121-00-98	PLATE, BRAKE SHOE	1	1	1	1	LGB
6	93109-34057	OIL SEAL	1	1	1	1	
7	3PT-W253A-10	BRAKE SHOE KIT	1	1	1	1	
8	2E9-25133-00	.SPRING, RETURN	1	1	1	1	
9	90336-15033	PLUG, TAPER	1	1	1	1	
10	2T4-25155-00	LEVER, CAMSHAFT 1	1	1	1	1	
11	2E9-25151-01	CAMSHAFT	1	1	1	1	
12	97007-05020	BOLT	1	1	1	1	
13	95307-05600	NUT	1	1	1	1	
14	94125-10650	TIRE (2.50-10)	1	1	1	1	UR INOUE
	94125-10651	TIRE (2.50-10 4PR M29)	1	1	1	1	UR BRIDGESTONE
15	94225-10270	TUBE (2.50/2.75-10)	1	1	1	1	INOUE
16	93306-20006	BEARING	2	2	2	2	NTN
17	2T4-25185-00	RING 1	1	1	1	1	
18	4N0-25181-01	AXLE, WHEEL	1	1	1	1	
19	90387-10620	COLLAR	1	1	1	1	
20	90185-10091	NUT, SELF-LOCKING	1	1	1	1	
21	92903-10200	WASHER, PLAIN	1	1	1	1	
22	36E-2539F-00	PLATE 1	3				

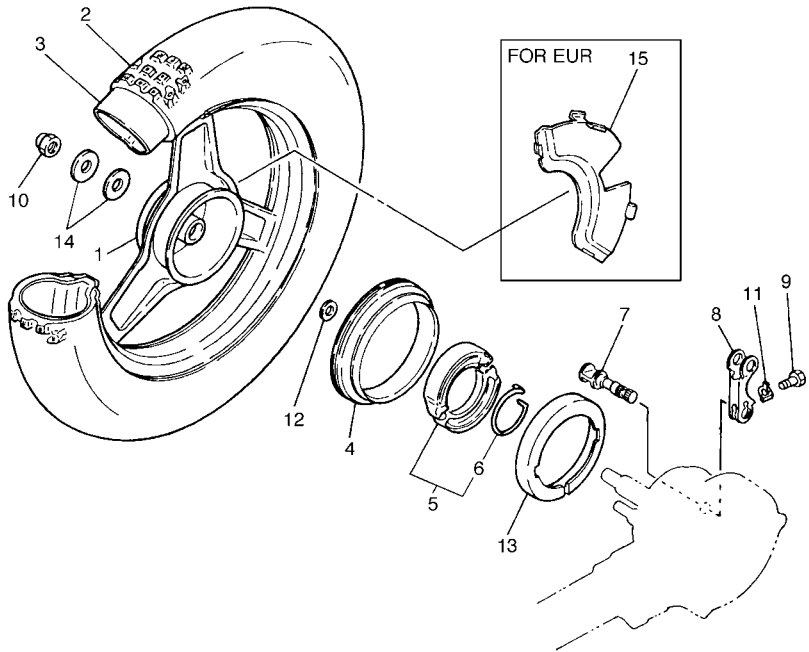
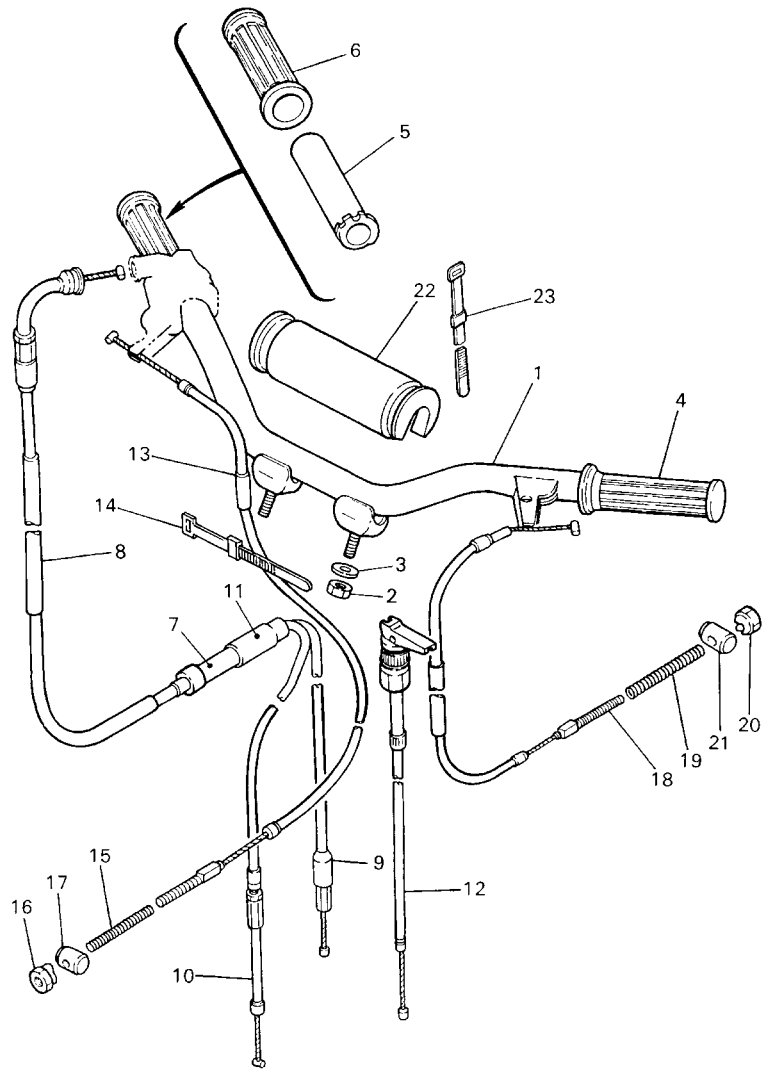

FIG. 21 REAR WHEEL

REF. NO.	PART NO.	DESCRIPTION	EUR	ZAF	JPN	OCE	REMARKS
1	5M0-25390-00-UJ	REAR WHEEL COMP.	1	1	1	1	RW
2	94125-10650	TIRE (2.50-10)	1	1	1	1	UR INOUE
	94125-10651	TIRE (2.50-10 4PR M29)	1	1	1	1	UR BRIDGESTONE
3	94225-10270	TUBE (2.50/2.75-10)	1	1	1	1	INOUE
4	2T4-25185-00	RING 1	1	1	1	1	
5	3PT-W253A-10	BRAKE SHOE KIT	1	1	1	1	
6	2E9-25133-00	.SPRING, RETURN	1	1	1	1	
7	3L5-25351-00	CAMSHAFT	1	1	1	1	
8	3L5-25355-00	LEVER, CAMSHAFT	1	1	1	1	
9	90101-05396	BOLT	1	1	1	1	
10	90185-12046	NUT, SELF-LOCKING	1	1	1	1	
11	2E9-25412-00	WASHER	1	1	1	1	
12	90201-15700	WASHER, PLATE	1	1	1	1	
13	4X4-25336-00	RING 2	1	1	1	1	
14	90387-125A5	COLLAR	2	2	2	2	
15	36E-2539F-00	PLATE 1	3				



5PG8300-C210



5PG5100-B220

FIG. 22 STEERING HANDLE & CABLE

REF. NO.	PART NO.	DESCRIPTION	EUR	ZAF	JPN	OCE	REMARKS
1	3PT-26111-00	HANDLEBAR	1	1	1	1	
2	95607-08100	NUT, U	2	2	2	2	
3	2E9-26129-00	WASHER	2	2	2	2	
4	4X4-26241-00	GRIP	1	1	1	1	
5	4X4-26243-00	TUBE, THROTTLE GUIDE	1	1	1	1	
6	4X4-26242-00	GRIP (RIGHT)	1	1	1	1	
7	266-26261-00	CONNECTOR, CABLE	1	1	1	1	
8	4X4-26311-10	CABLE, THROTTLE 1	1	1	1	1	
9	5PG-26312-00	CABLE, THROTTLE 2	1	1	1	1	
10	4X4-26321-10	CABLE, PUMP	1	1	1	1	
11	5L6-26272-00	CAP	1	1	1	1	
12	4X4-26331-01	CABLE, STARTER 1	1	1	1	1	
13	3PT-26341-00	WIRE, BRAKE 1	1	1	1	1	
14	3TB-83936-00	BAND, SWITCH CORD	1	1	1	1	
15	90501-10513	SPRING, COMPRESSION	1	1	1	1	
16	90179-06411	NUT	1	1	1	1	
17	90249-12008	PIN	1	1	1	1	
18	4X4-26351-10	CABLE, BRAKE	1	1	1	1	
19	90501-10074	SPRING, COMPRESSION	1	1	1	1	
20	90179-06411	NUT	1	1	1	1	
21	90249-12008	PIN	1	1	1	1	
22	36R-26124-10	PROTECTOR, HANDLEBAR	1	1	1	1	
23	437-83936-11	BAND, SWITCH CORD	2	2	2	2	

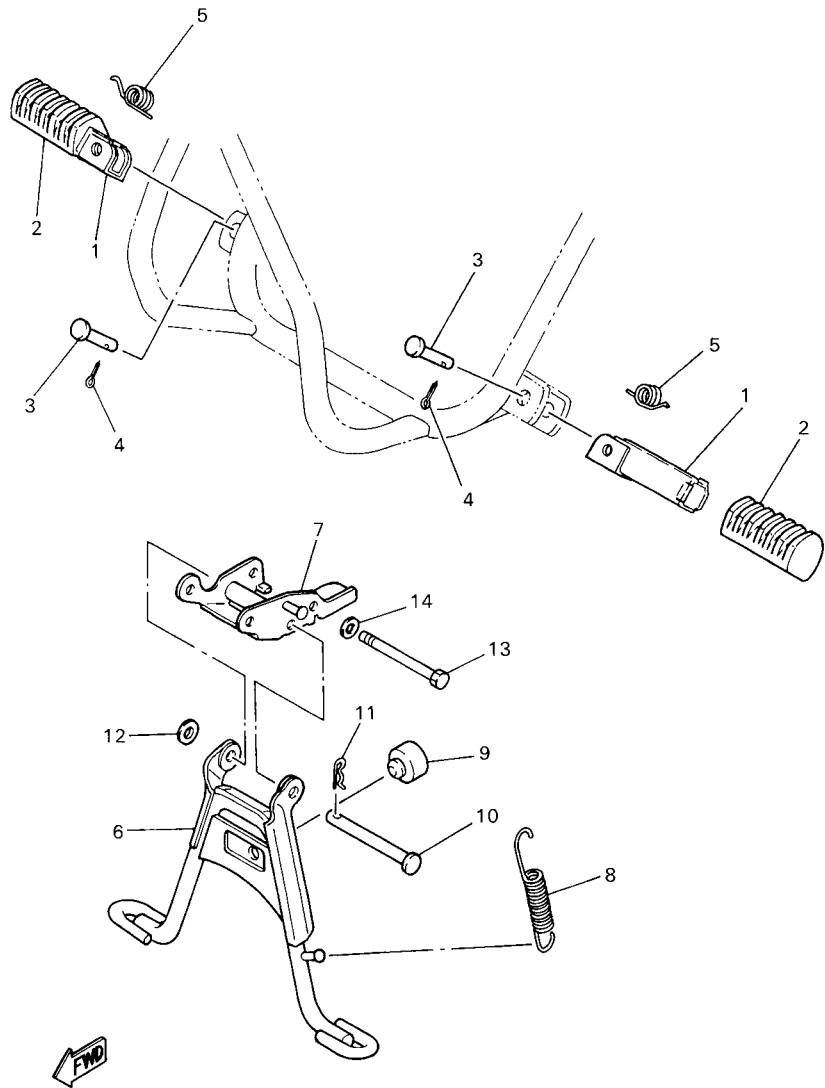

5PG5100-B230

FIG. 23 STAND & FOOTREST

REF. NO.	PART NO.	DESCRIPTION	EUR	ZAF	JPN	OCE	REMARKS
1	214-27421-00	FOOTREST 2	2	2	2	2	
2	4X4-27413-00	COVER, FOOTREST	2	2	2	2	
3	90240-08084	PIN, CLEVIS	2	2	2	2	
4	91401-25015	PIN, COTTER	2	2	2	2	
5	90508-20023	SPRING, TORSION	2	2	2	2	
6	4X4-27111-00-33	STAND, MAIN	1	1	1	1	YB
7	3L5-27151-02	BRACKET, MAIN STAND	1	1	1	1	
8	90506-29052	SPRING, TENSION	1	1	1	1	
9	4X4-27114-00	STOPPER, MAIN STAND	1	1	1	1	
10	91701-08078	PIN	1	1	1	1	
11	90468-12006	CLIP	1	1	1	1	
12	92907-08600	WASHER, PLATE	1	1	1	1	
13	91317-06070	BOLT	2	2	2	2	
14	90201-06045	WASHER, PLATE	2	2	2	2	

FIG. 24 GENERATOR

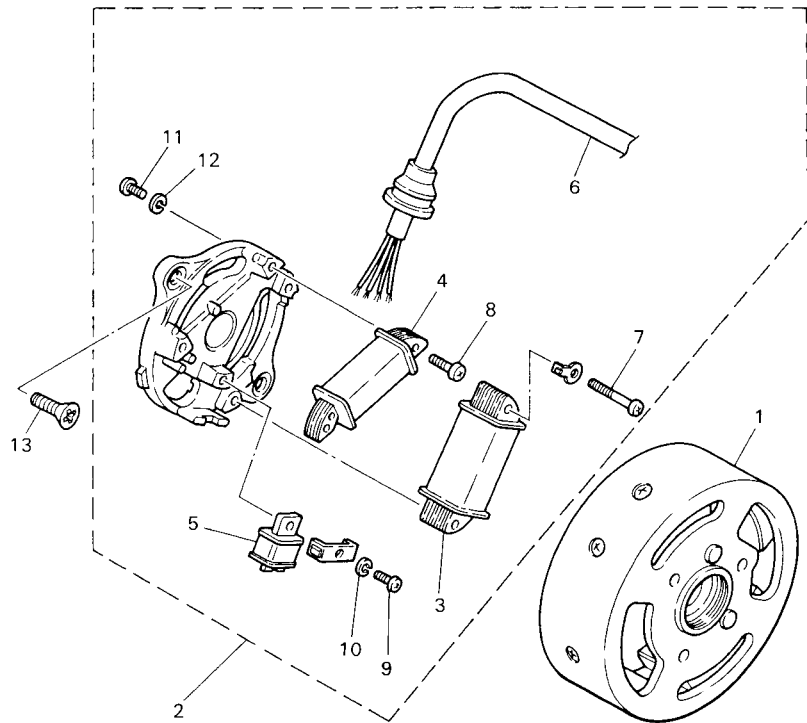

5PG1100-1240

REF. NO.	PART NO.	DESCRIPTION	EUR	ZAF	JPN	OCE	REMARKS
1	3L6-85550-M1	ROTOR ASSY	1	1	1	1	
2	3PT-85560-00	BASE ASSY	1	1	1	1	
3	4X4-81313-M0	.COIL, LIGHTING 1	1	1	1	1	
4	4Y4-85520-M0	.COIL, CHARGE	1	1	1	1	
5	3L5-85580-M0	.COIL, PULSER	1	1	1	1	
6	3PT-8131X-00	.CORD ASSY	1	1	1	1	
7	98517-04025	.SCREW, PAN HEAD	2	2	2	2	
8	98517-04012	.SCREW, PAN HEAD	2	2	2	2	
9	98507-04010	.SCREW, PAN HEAD	1	1	1	1	
10	92907-04100	.WASHER, SPRING	1	1	1	1	
11	98507-04006	.SCREW, PAN HEAD	1	1	1	1	
12	92907-04100	.WASHER, SPRING	1	1	1	1	
13	98707-06016	SCREW, FLAT HEAD	2	2	2	2	

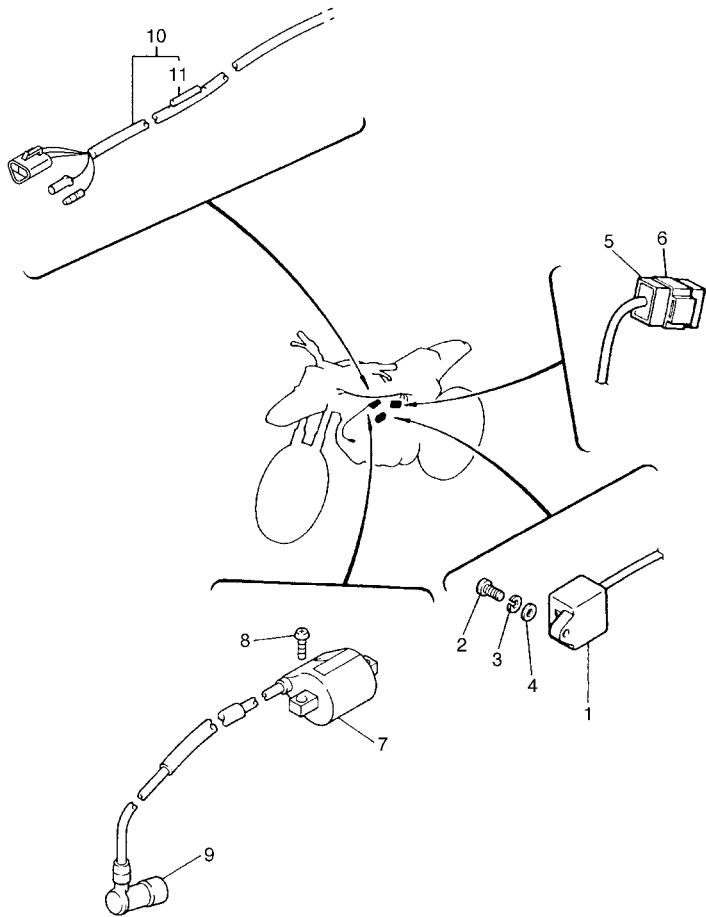

FIG. 26 ELECTRICAL 1

REF. NO.	PART NO.	DESCRIPTION	EUR	ZAF	JPN	OCE	REMARKS
1	3PT-85540-00	C.D.I. UNIT ASSY	1	1	1	1	
2	98507-06016	SCREW, PAN HEAD	1	1	1	1	
3	92907-06100	WASHER, SPRING	1	1	1	1	
4	92907-06600	WASHER, PLATE	1	1	1	1	
5	5PG-85590-00	CONTROL UNIT ASSY	1	1	1	1	
6	4J2-85546-00	BAND	1	1	1	1	
7	4JP-82310-00	IGNITION COIL ASSY	1	1	1	1	
8	97007-06016	BOLT	2	2	2	2	
9	166-82370-20	PLUG CAP ASSY	1	1	1	1	
10	5PG-82590-00	WIRE HARNESS ASSY	1	1	1	1	
11	3K7-81980-00	.DIODE ASSY	1	1	1	1	

NUMERICAL INDEX

PART NO.	REF. NO.	PART NO.	REF. NO.	PART NO.	REF. NO.	PART NO.	REF. NO.	PART NO.	REF. NO.	PART NO.	REF. NO.
4J2-11111-00	1 - 1	4X4-14411-00	4 - 11	3L5-17473-00	10 - 4	3HA-24141-00	11 - 4	4X4-28100-00	13 - 11	90159-06013	4 - 19
517-11181-01	1 - 2	4X4-14412-00	4 - 12	3L5-17531-00	10 - 2	59V-24173-00	18 - 12	5PG-2816R-00	13 - 10	90159-06058	13 - 9
4J2-11311-00	1 - 4	4X4-14451-00	4 - 13	3L5-17537-00	10 - 8	3R0-24181-00	18 - 11	4J2-46110-01	16 - 8	90159-06060	12 - 2
3PT-11351-00	1 - 5	4X4-14453-00	4 - 16	15L-17552-00	10 - 6	4X4-24181-00	13 - 5	3L5-46114-00	16 - 11		17 - 25
3L5-11400-01	2 - 1	4X4-14493-01	4 - 18	15L-18473-00	16 - 20	5PG-24240-10	18 - 19	59M-46121-00	16 - 2	90170-10105	3 - 7
3L5-11412-00	2 - 2	4X4-14610-01	6 - 1	36E-21110-01-33	11 - 1	5PG-24311-10	18 - 13	3L5-46127-00	16 - 4	90170-10206	9 - 9
3L5-11422-01	2 - 3	4X4-14623-10	6 - 2	5PA-2118K-20	12 - 5	4X4-24500-00	18 - 4	4J2-46151-01	16 - 1	90179-06411	22 - 16
260-11610-04	2 - 16	4X4-14708-00	6 - 7	3PT-21511-20	12 - 1	2FG-24610-00	18 - 2	4J2-46154-02	16 - 13		22 - 20
260-11610-14	2 - 16	4X4-14714-00	6 - 11	36E-21513-00	12 - 4	5PG-2467E-00	18 - 10	3L7-46171-00	16 - 18	90185-10091	20 - 20
260-11610-24	2 - 16	4X4-14750-00	6 - 13	4X4-21543-00	17 - 24	5PG-24710-00	19 - 1	4X4-81313-M0	24 - 3	90185-12046	21 - 10
18U-11631-00-A0	2 - 14	3RV-14766-00	6 - 10	5PA-21568-01	13 - 10	5PG-24711-00	19 - 2	3PT-8131X-00	24 - 6	90201-06033	13 - 3
3L5-11633-00	2 - 15	5PG-1490J-00	5 - 15	3PT-21569-80	12 - 3	2E9-25116-00	20 - 3	3K7-81980-00	26 - 11	90201-06045	23 - 14
18U-11635-00	2 - 14	55X-14937-00	5 - 27	4X4-21629-00	14 - 9	2T4-25121-00-98	20 - 5	4JP-82310-00	26 - 7	90201-06747	18 - 6
18U-11636-00	2 - 14	1M3-14997-00	5 - 25	3XJ-21668-10	15 - 12	2E9-25133-00	20 - 8	166-82370-20	26 - 9	90201-067A0	15 - 17
2E9-11651-00	2 - 5	4X4-15111-00	7 - 1	3RV-21668-A0	15 - 12		21 - 6	5PG-82590-00	26 - 10	90201-08326	15 - 10
54U-11681-00	2 - 4	4J2-15113-00	7 - 21	3PT-21711-10	13 - 1	2E9-25151-01	20 - 11	5PG-82920-00	25 - 4	90201-105H3	17 - 19
3L5-13101-01	3 - 1	4J2-15121-01	7 - 4	4X4-2172K-00	14 - 7	2T4-25155-00	20 - 10	2T4-83912-02	25 - 1	90201-126A7	15 - 16
3L5-13124-00	3 - 9	3L5-15128-00	7 - 5	3PT-21731-60	13 - 7	5M0-25180-00-UJ	20 - 1	2T4-83922-02	25 - 5	90201-15700	21 - 12
384-13138-00	3 - 6	2E9-15316-00	7 - 7	3PT-2173L-B0	13 - 6	4N0-25181-01	20 - 18	3TB-83936-00	22 - 14	90201-16383	9 - 11
3L5-13161-00	3 - 12	4J2-15363-10	7 - 18	3PT-21741-60	13 - 8	2T4-25185-00	20 - 17		25 - 10	90202-04214	6 - 9
3L5-13178-00	8 - 9	4J2-15415-00	7 - 8	4X4-21751-00	14 - 1		21 - 4	437-83936-01	25 - 9	90208-10012	9 - 8
3L5-13555-00	4 - 9	3L5-15416-00	3 - 16	4X4-21766-01	14 - 4	4X4-25336-00	21 - 13	437-83936-11	22 - 23	90209-10160	17 - 18
3L5-13610-00	4 - 1	4X4-15421-02	7 - 10	1Y1-21770-01	14 - 2	3L5-25351-00	21 - 7	4Y4-85520-M0	24 - 4	90240-08084	23 - 3
3L5-13613-00	4 - 2	3L5-15426-00	3 - 17	4X4-21773-00	14 - 8	3L5-25355-00	21 - 8	3PT-85540-00	26 - 1	90249-12008	22 - 17
3L5-13616-00	4 - 3	3L5-15451-11	7 - 13	3L7-22110-00-98	15 - 1	5M0-25390-00-UJ	21 - 1	4J2-85546-00	26 - 6		22 - 21
3HK-13621-00	4 - 7	4X4-15484-00	7 - 25	4X4-22110-10	15 - 4	36E-2539F-00	20 - 22	3L6-85550-M1	24 - 1	90280-03017	2 - 7
3L5-13622-10	4 - 8	4X4-15491-00	7 - 24	4J2-22174-01	15 - 5		21 - 15	3PT-85560-00	24 - 2	90282-05034	9 - 7
3L5-13624-00	4 - 6	3L5-15601-00	8 - 1	3PT-22210-10	15 - 13	2E9-25412-00	21 - 11	3L5-85580-M0	24 - 5	90336-15033	20 - 9
5PG-14101-10	5 - 1	2T4-15618-00	8 - 5	164-22216-00	15 - 11	3PT-26111-00	22 - 1	5PG-85590-00	26 - 5	90387-077F4	18 - 7
36R-14103-00	5 - 17	17J-15620-01	8 - 4		16 - 15	36R-26124-10	22 - 22	3PT-W253A-10	20 - 7	90387-10620	20 - 19
36R-14104-00	5 - 21	3L5-15631-00	8 - 7	3PT-23100-01-35	17 - 1	2E9-26129-00	22 - 3		21 - 5	90387-125A5	21 - 14
17L-14106-00	5 - 9	3L5-15664-00	8 - 2	3PT-23103-00-35	17 - 14	4X4-26241-00	22 - 4	90101-05396	21 - 9	90387-16730	9 - 6
3L5-14112-40	5 - 14	3L5-15673-00	8 - 8	4X4-23106-00-35	17 - 10	4X4-26242-00	22 - 6	90101-08461	15 - 2	90401-10029	3 - 8
174-14131-01	5 - 16	3L5-16111-00	9 - 1	3PT-23110-00	17 - 4	4X4-26243-00	22 - 5	90105-08066	15 - 8	90430-04004	3 - 4
127-14135-00	5 - 19	3L5-16114-00	9 - 4	2E9-23113-01	17 - 8	4X4-26257-00	25 - 11	90105-08103	7 - 16	90430-08119	7 - 17
3L7-14141-12	5 - 4	3L5-16115-00	9 - 2	54V-23125-02	17 - 7	266-26261-00	22 - 7	90105-08121	15 - 18	90445-09251	18 - 3
3L5-14142-40	5 - 5	3L5-16125-00	9 - 3	4X4-23141-00	17 - 11	5L6-26272-00	22 - 11	90105-10006	17 - 17	90445-095J0	18 - 15
1R0-14169-00	5 - 10	3L5-16181-01	9 - 5	2E9-23143-00	17 - 13	4X4-26311-10	22 - 8	90105-10110	11 - 3	90465-10098	25 - 12
3XV-14169-00	5 - 28	3L5-16611-02	9 - 17	2E9-23144-01	17 - 5	5PG-26312-00	22 - 9	90109-08582	7 - 20	90467-08003	14 - 6
127-14171-00	5 - 18	3L5-16620-03	9 - 12	36R-23151-00	17 - 9	4X4-26321-10	22 - 10	90116-06418	1 - 6		18 - 16
3L5-14184-00	5 - 2	3L5-16627-02	9 - 15	3L6-23195-00	17 - 12	4X4-26331-01	22 - 12	90119-06226	13 - 4	90467-12052	18 - 14
3L6-14185-01	5 - 11	3L5-16628-02	9 - 13	3PT-23340-00	17 - 2	3PT-26341-00	22 - 13	90149-04135	3 - 5	90467-20023	4 - 17
603-14186-00	5 - 13	2T4-16629-00	9 - 14	3PT-23411-00	17 - 22	4X4-26351-10	22 - 18	90149-05119	25 - 6	90467-22048	6 - 12
3L5-14190-01	5 - 12	3L5-16633-02	9 - 16	2E9-23412-00	17 - 20	4X4-27111-00-33	23 - 6	90149-05162	25 - 2	90468-02033	3 - 13
214-14197-00	5 - 24	3L5-17112-01	7 - 11	2E9-23413-01	17 - 21	4X4-27114-00	23 - 9	90149-35133	16 - 6	90468-12006	23 - 11
3L5-14198-00	5 - 8	3L5-17410-00	10 - 1	3YJ-23414-00	17 - 3	3L5-27151-02	23 - 7	90149-45134	10 - 10	90480-10408	14 - 3
620-14231-14	5 - 3	3L5-17442-00	10 - 9	4X4-23435-00	17 - 16	4X4-27413-00	23 - 2	90153-06011	6 - 3	90480-18290	18 - 5
1V3-14271-00	5 - 26	3L5-17471-00	10 - 3	5PG-24110-10	18 - 1	214-27421-00	23 - 1	90157-05003	6 - 8	90501-08410	14 - 5

NUMERICAL INDEX

PART NO.	REF. NO.	PART NO.	REF. NO.	PART NO.	REF. NO.	PART NO.	REF. NO.	PART NO.	REF. NO.	PART NO.	REF. NO.
90501-10074	22 - 19	93306-20111	16 - 5	98507-05014	7 - 9						
90501-10513	22 - 15	93306-20117	15 - 6	98507-05020	3 - 14						
90501-60556	16 - 19	93306-20203	16 - 9	98507-05025	25 - 7						
90506-29052	23 - 8	93306-20205	16 - 16	98507-05030	5 - 23						
90508-20023	23 - 5	93306-20301	10 - 7	98507-05035	3 - 15						
90508-28399	8 - 3	93306-20326	2 - 11	98507-06008	6 - 14						
90560-10173	20 - 2	93310-21038	2 - 18	98507-06010	18 - 17						
90560-15315	16 - 10	93310-416N7	2 - 6	98507-06012	7 - 6						
90560-25185	16 - 7	93430-07012	3 - 11		7 - 22						
91317-06070	23 - 13	93440-17138	16 - 21	98507-06016	26 - 2						
91318-06016	10 - 5	93450-11021	2 - 17	98507-06020	4 - 10						
91401-25015	23 - 4	93450-30057	17 - 6	98507-06025	7 - 15						
91609-30014	3 - 10	93505-32042	17 - 23	98507-06035	7 - 14						
91701-08078	23 - 10	94125-10650	20 - 14	98507-06045	4 - 14						
92903-10200	20 - 21		21 - 2		7 - 3						
92907-03100	4 - 5	94125-10651	20 - 14	98517-04012	24 - 8						
92907-04100	5 - 7		21 - 2	98517-04025	24 - 7						
	24 - 10	94225-10270	20 - 15	98607-05112	5 - 20						
	24 - 12		21 - 3	98707-06016	24 - 13						
92907-06100	6 - 15	94701-00159	1 - 3	98807-05100	5 - 22						
	6 - 18	94701-00171	1 - 3	99009-16400	9 - 10						
	7 - 23	94701-00258	1 - 3		9 - 18						
	15 - 15	94703-00258	1 - 3	99530-12016	7 - 2						
	26 - 3	95027-06016	16 - 14		7 - 12						
92907-06600	4 - 15	95027-08030	17 - 15								
	6 - 16	95307-05600	20 - 13								
	6 - 19	95307-12700	2 - 10								
	18 - 18	95607-05100	25 - 3								
	26 - 4		25 - 8								
92907-08100	6 - 5	95607-08100	22 - 2								
	15 - 3	95607-10200	11 - 2								
92907-08600	6 - 6	95707-06500	1 - 7								
	23 - 12		18 - 9								
92907-12100	2 - 9	95707-08500	15 - 9								
92907-12600	2 - 8	97002-06016	13 - 2								
93101-10001	3 - 2	97007-05020	20 - 12								
93102-15267	10 - 11	97007-06016	6 - 17								
93102-17067	2 - 12		26 - 8								
93102-23174	2 - 13	97007-06090	18 - 8								
93106-17015	20 - 4	97007-08020	6 - 4								
93106-24018	15 - 7	97017-06016	16 - 12								
93109-15001	8 - 10	97017-06025	8 - 6								
93109-34057	20 - 6	97027-06016	15 - 14								
93210-14104	7 - 19	97707-50115	3 - 18								
93210-26240	3 - 3	98507-03010	4 - 4								
93211-066A9	16 - 17	98507-04006	24 - 11								
93306-20006	20 - 16	98507-04010	24 - 9								
93306-20111	16 - 3	98507-04014	5 - 6								